

GN 282

Pivoting connecting clamps

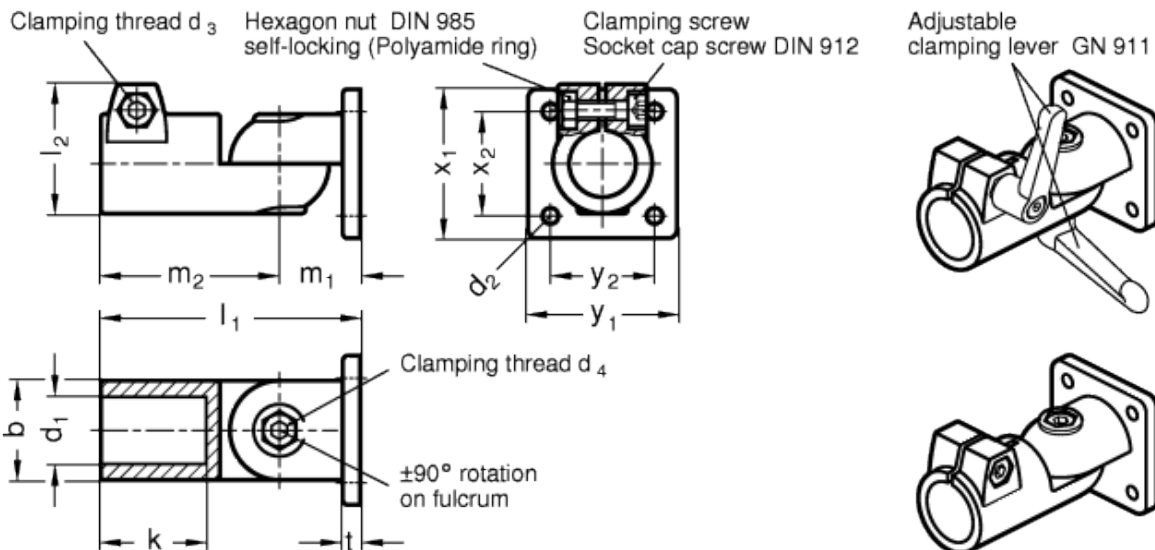

technical informations

Material
Aluminium.

Finish

- Version SW: RAL 9005 black colour, matte finish, epoxy resin coating.
- Version BL: blank, matte shot-blasted.

Types

- Type S: steppless adjustment.
- Type T: adjustment by 15° -division (serration).

Clamping screws

Identification no. 2: with three AISI 304 stainless steel-clamping screws DIN 912 and nuts DIN 985.

Assembly

The standard clamping bolts are socket cap screws DIN 912, supplied assembled. They can be replaced by clamping kits GN 911 (description see table of dimensions).

Features and applications

The swivel clamp connector joints GN 282 are an assembly of the swivel clamp connectors GN 272 and GN 276.

For the type with stepless adjustment (Type S) swivel clamp connectors with a centring step are used.

The clamping bore is machined and designed for construction tubings GN 990 or DIN 2391, DIN 2395 and DIN 2462 respectively.

Accessories

- Tubings [GN 990](#).
- Clamping kits [GN 911](#) (clamping handles GN 300.1 with distance bushing).

Standard Elements	Main dimensions															Clamping kits		Weight
	Description	d ₁	b	d ₂	d ₃	d ₄	k	l ₁	l ₂	m ₁	m ₂	t	x ₁	x ₂	y ₁	y ₂	For d ₃	
GN 282-B20-S-2-*	B 20	40	6.5	M 8	M 8	42.5	104.5	52	32.5	72	7	60	42	60	42	GN 911-M8-32	GN 911-M8-35	242
GN 282-B25-S-2-*	B 25	40	6.5	M 8	M 8	42.5	104.5	52	32.5	72	7	60	42	60	42	GN 911-M8-32	GN 911-M8-35	275
GN 282-B30-S-2-*	B 30	40	6.5	M 8	M 8	42.5	104.5	52	32.5	72	7	60	42	60	42	GN 911-M8-32	GN 911-M8-35	200
GN 282-B40-S-2-*	B 40	65	11	M 10	M 10	74	167	77.5	52	115	14	105	74	105	74	GN 911-M10-55	GN 911-M10-63	1260
GN 282-B42-S-2-*	B 42	65	11	M 10	M 10	74	167	77.5	52	115	14	105	74	105	74	GN 911-M10-55	GN 911-M10-63	1340
GN 282-B45-S-2-*	B 45	65	11	M 10	M 10	74	167	77.5	52	115	14	105	74	105	74	GN 911-M10-55	GN 911-M10-63	1300
GN 282-B48-S-2-*	B 48	65	11	M 10	M 10	74	167	77.5	52	115	14	105	74	105	74	GN 911-M10-55	GN 911-M10-63	1250
GN 282-B50-S-2-*	B 50	65	11	M 10	M 10	74	167	77.5	52	115	14	105	74	105	74	GN 911-M10-55	GN 911-M10-63	1240
GN 282-B20-T-2-*	B 20	40	6.5	M 8	M 8	42.5	104.5	52	32.5	72	7	60	42	60	42	GN 911-M8-32	GN 911-M8-35	279
GN 282-B25-T-2-*	B 25	40	6.5	M 8	M 8	42.5	104.5	52	32.5	72	7	60	42	60	42	GN 911-M8-32	GN 911-M8-35	310
GN 282-B30-T-2-*	B 30	40	6.5	M 8	M 8	42.5	104.5	52	32.5	72	7	60	42	60	42	GN 911-M8-32	GN 911-M8-35	235
GN 282-B40-T-2-*	B 40	65	11	M 10	M 10	74	167	77.5	52	115	14	105	74	105	74	GN 911-M10-55	GN 911-M10-63	300
GN 282-B42-T-2-*	B 42	65	11	M 10	M 10	74	167	77.5	52	115	14	105	74	105	74	GN 911-M10-55	GN 911-M10-63	1340
GN 282-B45-T-2-*	B 45	65	11	M 10	M 10	74	167	77.5	52	115	14	105	74	105	74	GN 911-M10-55	GN 911-M10-63	1310
GN 282-B48-T-2-*	B 48	65	11	M 10	M 10	74	167	77.5	52	115	14	105	74	105	74	GN 911-M10-55	GN 911-M10-63	1260
GN 282-B50-T-2-*	B 50	65	11	M 10	M 10	74	167	77.5	52	115	14	105	74	105	74	GN 911-M10-55	GN 911-M10-63	1250

* Complete the description of the standard item needed by adding the finish of the connector clamps: BL (blank) or SW (black).



STANDARD MACHINE ELEMENTS WORLDWIDE